

USERS' MANUAL

WIRELESS TILT METER WITH IN-BUILT DATALOGGER

Model ESDL-30MT



Doc. # WI 6002.110 R01 | Aug 2025



TUNNELS



HYDROELECTRIC



CONSTRUCTION



STRUCTURAL



METRO & RAIL



BRIDGES



MINING

CONTENT

1	INTRODUCTION	1
2	DESCRIPTION	2
3	INSTALLATION	3
4	SIGN CONVENTION	4
5	CONFIGURATION, DATA RETRIEVAL	5
5.1	Configuration	5
5.2	Online data via telemetry transmission through GSM/GPRS modem	5
5.3	Readout/data retrieval using laptop PC	5
6	PROTECTION	6
7	SAMPLE CERTIFICATE	7
8	ENVIRONMENTAL RESPONSIBILITY DECLARATION	9
9	WARRANTY	10

1 INTRODUCTION

The Encardio Rite Model ESDL-30MT is a wireless tilt meter integrated with an automatic datalogger, designed for reliable and accurate online monitoring of structural inclination. The unit incorporates a rugged biaxial MEMS tilt sensor, making it a complete standalone solution for tilt monitoring in diverse field applications.

The system not only measures tilt but also provides flexibility to connect additional sensors such as nearby-installed crack meters, other tilt meters, or vibrating wire/resistive strain gauge type sensors via its SDI-12 interface.

Engineered for remote monitoring, the ESDL-30MT is ideally suited for structures including buildings, metros, tunnels, underground cavities, dams, mines, high-rise buildings, historical monuments, bridges, and retaining walls. Its wireless data transmission and integrated data storage capabilities make it particularly effective in hard-to-access locations requiring precise and continuous observation.

With programmable measurement intervals ranging from 5 seconds to 168 hours, the unit offers adaptability for short-term or long-term monitoring programs. However, as the unit operates primarily on battery power, higher measurement frequencies may reduce battery life and should be configured according to monitoring needs.

By delivering real-time, high-quality data, the ESDL-30MT enables project authorities and engineers to detect even the smallest changes in structural tilt, thereby supporting timely decision-making, enhancing safety, minimizing project delays, and improving cost-effectiveness.

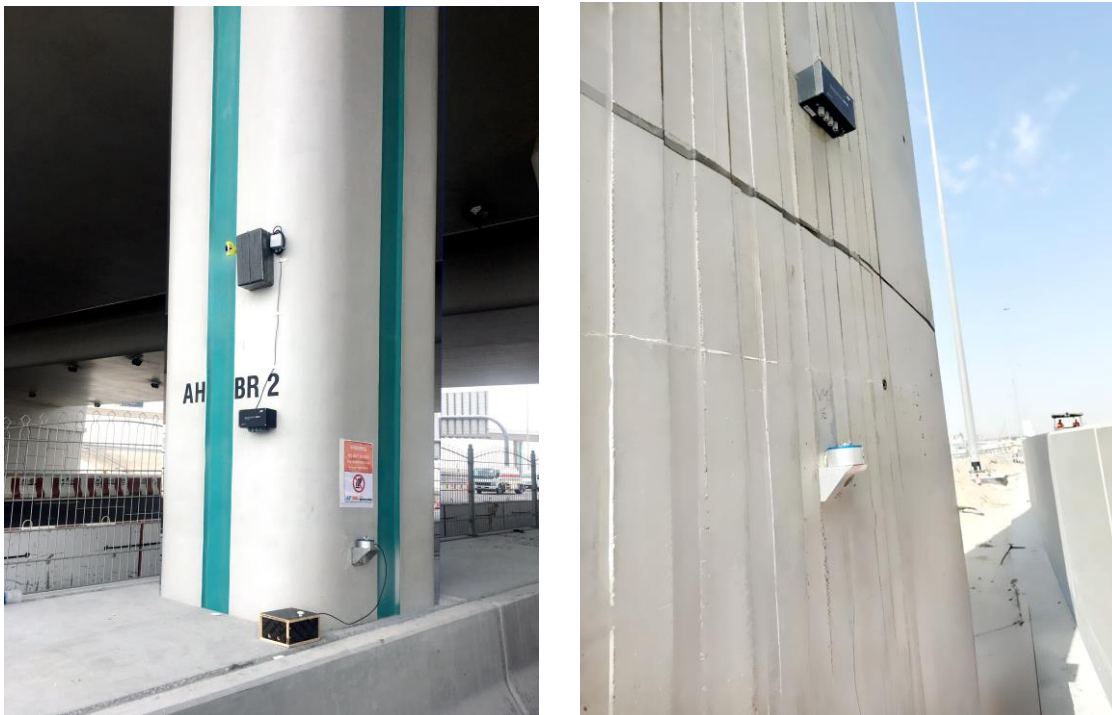

Figure 1: ESDL-30MT tilt meter installed at a site

2 DESCRIPTION

Figure 2 shows model ESDL-30MT wireless tilt meter with in-built datalogger. The biaxial tilt sensor is connected at Channel 1. Channel 2 and Channel 3 can be used for other sensors to measure different parameters. In figure below an interface suitable for vibrating wire, resistive strain gage type or 4-20 mA output sensor is shown connected to channel 2 and an IPI sensor/tilt meter with SDI-12 output is shown connected to channel 3 as an example.

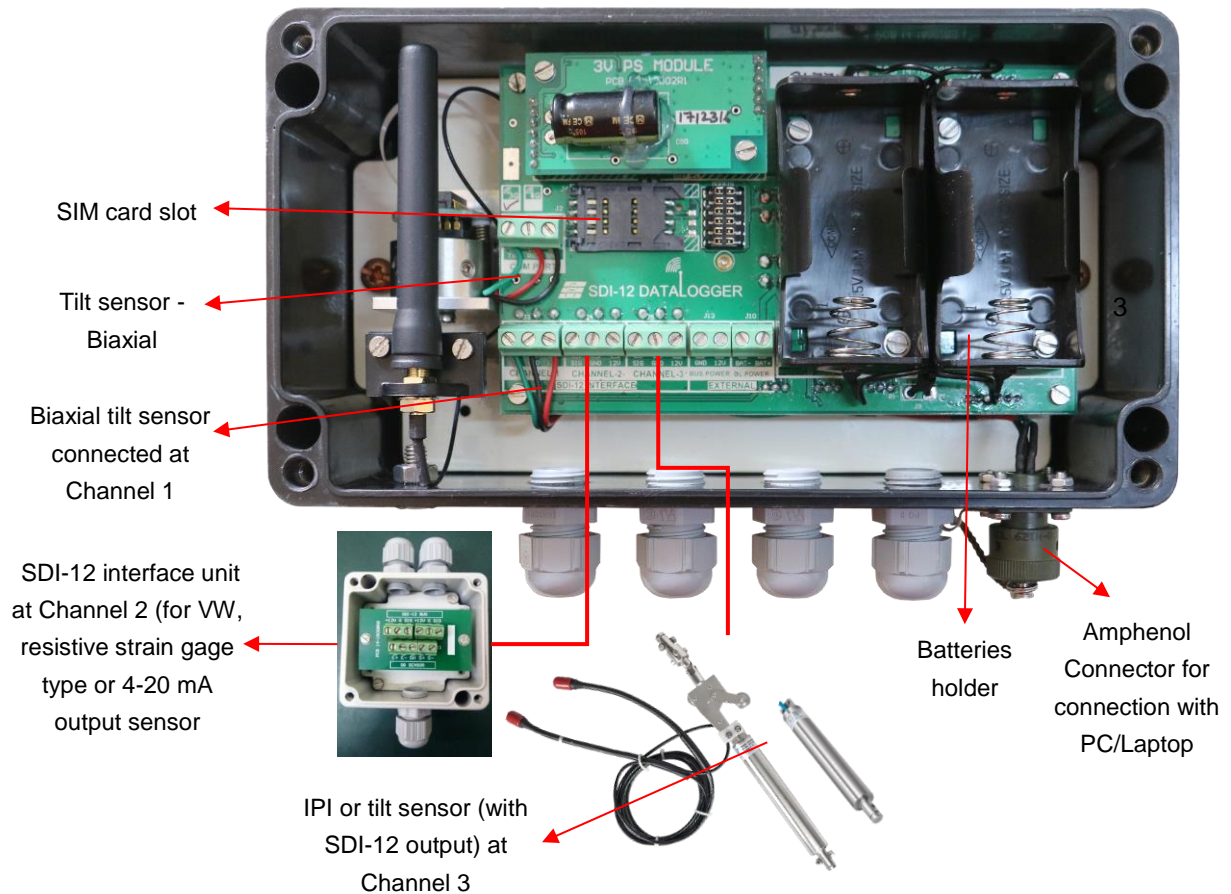

Figure 2: Details of model ESDL-30MT Wireless Tilt Meter with In-Built Datalogger

3 INSTALLATION

Typical mounting arrangement of model ESDL-30MT tilt meter (inside datalogger) on wall is shown in figure 3 below. Mounting arrangement of the same may differ depending on the location at which it is being installed. Please contact factory in case any special mounting arrangement is required.

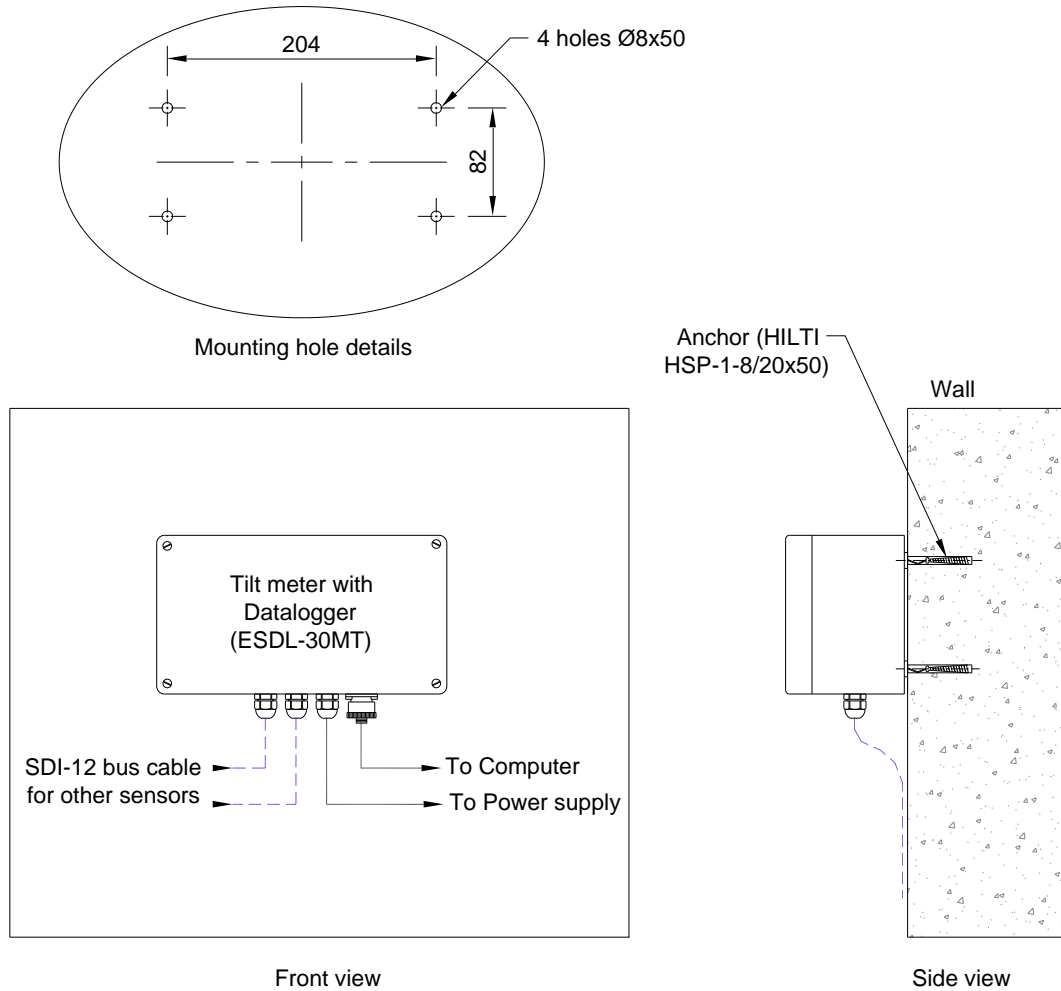

Figure 3: Installation details of model ESDL-30MT datalogger

4 SIGN CONVENTION

The ESDL-30MT wireless tilt meter with in-built datalogger measures angular tilt along two axes: A-axis (horizontal, left–right) and B-axis (vertical, forward–backward), as marked on the enclosure. The sign convention for interpreting tilt readings is as follows:

A-Axis (Front View)

A+ (Positive Tilt): When the top of the unit tilts to the left (from the user's perspective facing the front panel, in the +A direction as per enclosure marking).

A- (Negative Tilt): When the top of the unit tilts to the right (from the user's perspective facing the front panel).

B-Axis (Side View)

B+ (Positive Tilt): When the top of the unit tilts backward/upward (in the +B direction as per enclosure marking).

B- (Negative Tilt): When the top of the unit tilts forward/downward (towards the ground).

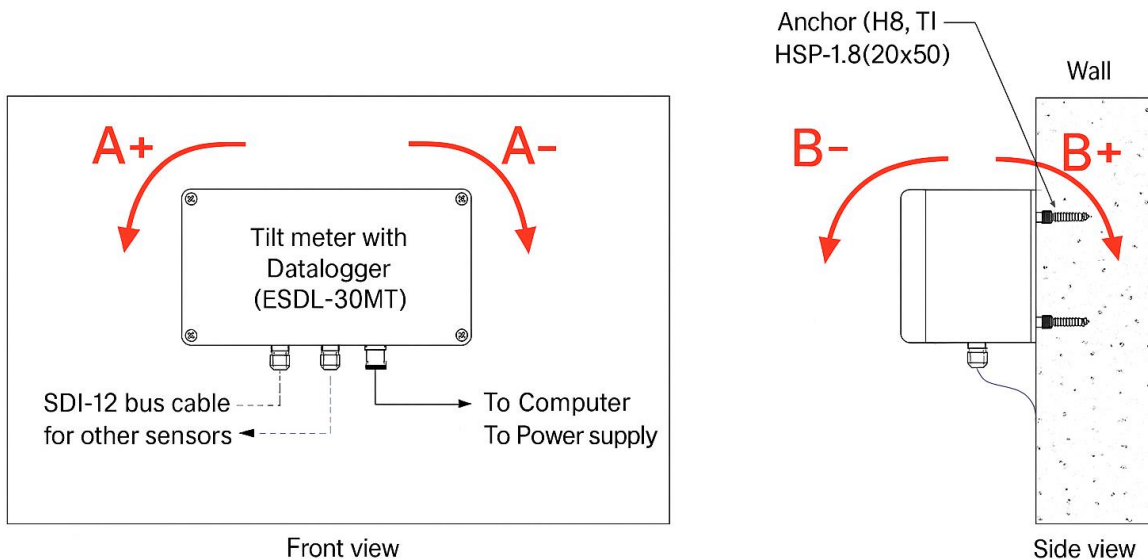

Figure 4: Sign convention

5 CONFIGURATION, DATA RETRIEVAL

5.1 Configuration

For configuration of ESDL-30MT wireless tilt meter with in-built datalogger, please refer to manual # WI 6002.110 for model ESDL-30 datalogger. The configuration is same for both models.

5.2 Online data via telemetry transmission through GSM/GPRS modem

In a location covered by any GSM/GPRS service provider, data from the automatic datalogger can be transmitted remotely to any server/cloud. A data SIM card is required for each datalogger (in customer's scope).

5.3 Readout/data retrieval using laptop PC

The logged data from datalogger installed in field can be directly downloaded to a laptop. Data can be then transferred to central PC or server from the laptop using either a USB pen drive or through Internet.

6 PROTECTION

Avoid installation of the tilt meter in parts of the structure exposed to direct sunlight. If this is not feasible, a box made from **Thermocole (polystyrene foam)** or similar heat-insulating material should be installed to cover the tilt meter and protect it from direct sunlight. If a certain degree of mechanical protection is also required, wooden or fiberglass protection boxes may be considered. Heat-insulating tape can be fixed to the inner surface of such boxes for additional thermal insulation.

7 SAMPLE CERTIFICATE

**TEST CERTIFICATE
(for 'A' axis calibration)**

Item : SDI-12 datalogger with built in tilt meter (Biaxial)
 Model : ESDL-30R1 MT
 Range : ±15° Date : 02.01.2019
 Serial No. : 1803501 Temperature : 17 °C
 Next calibration due on :01.01.2020

Test data

Test position Arc degrees(B)	Corresponding SinA	Observed SinA 'A' axis	Offset corrected SinA 'A' axis	Non-conformance (% fs) 'A' axis
15	0.2588	0.2593	0.2590	0.0695
12	0.2079	0.2081	0.2079	0.0119
9	0.1564	0.1567	0.1564	0.0013
6	0.1045	0.1049	0.1046	0.0211
3	0.0523	0.0526	0.0523	0.0043
0	0.0000	0.0003	0.0000	0.0000
-3	-0.0523	-0.0519	-0.0522	0.0483
-6	-0.1045	-0.1042	-0.1045	0.0079
-9	-0.1564	-0.1560	-0.1562	0.0763
-12	-0.2079	-0.2076	-0.2078	0.0292
-15	-0.2588	-0.2586	-0.2588	0.0093

Max non-conformance (% fs): 0.08

Calculation of tilt value (arc degree) :

$$A = \text{Sin}^{-1}(\text{observed output})$$

Wiring colour code :

Wire colour	Signal	Marking on PCB
Red	+ 12 V (supply)	12V
Black	0 V (supply)	GND
Green	Output signal	signal

- (1) One no. In-built Biaxial tilt meter has been connected at channel # 1.
- (2) Channel # 2 & 3 are free for other SDI sensors.

Tested by :

**TEST CERTIFICATE
(for 'B' axis calibration)**

Item : SDI-12 datalogger with built in tilt meter (Biaxial)
 Model : ESDL-30R1 MT
 Range : ±15° Date : 02.01.2019
 Serial No. : 1803501 Temperature : 17 °C
 Next calibration due on :01.01.2020

Test data

Test position	Corresponding SinA	Observed SinA 'B' axis	Offset corrected SinA 'B' axis	Non-conformance (% fs) 'B' axis
Arc degrees(B)				
15	0.2588	0.2584	0.2586	0.0808
12	0.2079	0.2075	0.2077	0.0992
9	0.1564	0.1560	0.1561	0.1153
6	0.1045	0.1042	0.1043	0.0693
3	0.0523	0.0521	0.0523	0.0093
0	0.0000	-0.0002	0.0000	0.0000
-3	-0.0523	-0.0524	-0.0522	0.0378
-6	-0.1045	-0.1046	-0.1045	0.0268
-9	-0.1564	-0.1567	-0.1565	0.0191
-12	-0.2079	-0.2082	-0.2081	0.0561
-15	-0.2588	-0.2590	-0.2589	0.0135

Max non-conformance (% fs): 0.12

Calculation of tilt value (arc degree) :

$$B = \text{Sin}^{-1}(\text{observed output})$$

Wiring colour code :

Wire colour	Signal	Marking on PCB
Red	+ 12 V (supply)	12V
Black	0 V (supply)	GND
Green	Output signal	signal

- (1) One no. In-built Biaxial tilt meter has been connected at channel # 1.
- (2) Channel # 2 & 3 are free for other SDI sensors.

Tested by :

8 ENVIRONMENTAL RESPONSIBILITY DECLARATION

Encardio Rite Group (“**Encardio**”) is committed to ensuring full compliance with environmental responsibilities under all applicable Indian environmental statutes, collectively referred to herein as the “**Law(s)**”. This declaration is applicable to all products manufactured and marketed by Encardio.

- 1. Scope:** This declaration binds and guides every stakeholder involved in the product’s lifecycle including individuals, institutions, organizations, or entities hereinafter referred to collectively as the “**User(s)**”.
- 2. Waste Segregation and Handling:** All Users are required to manage the product and any waste generated from its use in accordance with the law, including proper segregation of waste at the source into biodegradable, recyclable, and hazardous categories; authorized disposal of all end-of-life products, electronic components, batteries, and packaging materials only through government-authorized collection, recycling, or refurbishing systems; and ensuring that products bearing the crossed-out wheeled bin symbol are not mixed with general household or municipal waste streams.
- 3. E-Waste Disposal and Battery Waste Management:** All electronic and electrical equipment and components manufactured or sold by Encardio must be disposed of only through authorized recycling or refurbishing facilities as per applicable law, ensuring no harm to human health or the environment; users shall ensure that all used items are returned to designated collection points and shall also maintain proper documentation and adhere to return, reporting, or record-keeping obligations; products nearing end-of-life must not be discarded along with general household waste, as improper disposal of e-waste may lead to toxic chemical release and pollution.
- 4. Plastic Waste Management:** Users must not discard plastic components or packaging into unsorted municipal waste; instead, they should separate and hand over such plastic waste to authorized waste processors and ensure that no banned plastic items, as notified under law, are used or circulated.
- 5. Industrial and Hazardous Waste:** If the User operates any facility where industrial, hazardous, or biomedical waste may arise due to the installation, maintenance, or testing of the product, all necessary consents and permits must be obtained and renewed from competent authorities; adequate protective measures must be taken to ensure no harm is caused to the environment or human health; and such waste must be stored, treated, and disposed of in accordance with the law.
- 6. Pollution Control:** Users operating manufacturing, repair, or testing premises must not emit air or water pollutants beyond prescribed limits, must operate only after securing applicable consents under the law, and must maintain environmental records and submit reports as required
- 7. Record Keeping and Reporting:** All Users associated with Encardio must maintain comprehensive records of production, sales, collection, and disposal in accordance with applicable Law(s) and submit timely reports to regulatory authorities.
- 8. Contact and Support:** Encardio urges all Users to act responsibly and support sustainable environmental practices by adhering to this declaration and the Law. For safe disposal and further compliance assistance, Users are encouraged to contact their local municipal waste authorities, or authorized recyclers. Non-compliance with the above obligations may constitute a violation of Indian environmental laws and attract penalties under the relevant Law(s). Users can contact Encardio at:

Contact Number: +91 522 2661039-42

Website: <https://www.encardio.com/>

9 WARRANTY

The Company warrants its products against defective workmanship or material for a period of 12 months from date of receipt or 13 months from date of dispatch from the factory, whichever is earlier. The warranty is however void in case the product shows evidence of being tampered with or shows evidence of damage due to excessive heat, moisture, corrosion, vibration or improper use, application, specifications or other operating conditions not in control of Encardio Rite. The warranty is limited to free repair/replacement of the product/parts with manufacturing defects only and does not cover products/parts worn out due to normal wear and tear or damaged due to mishandling or improper installation. This includes fuses and batteries

If any of the products does not function or functions improperly, it should be returned freight prepaid to the factory for our evaluation. In case it is found defective, it will be replaced/repared free of cost.

A range of technical/scientific instruments are manufactured by Encardio Rite, the improper use of which is potentially dangerous. Only qualified personnel should install or use the instruments. Installation personnel must have a background of good installation practices as intricacies involved in installation are such that even if a single essential but apparently minor requirement is ignored or overlooked, the most reliable of instruments will be rendered useless.

The warranty is limited to as stated herein. Encardio Rite is not responsible for any consequential damages experienced by the user. There are no other warranties, expressed or implied, including but not limited to the implied warranties of merchantability and of fitness for a particular purpose. Encardio Rite is not responsible for any direct, indirect, incidental, special or consequential damage or loss caused to other equipment or people that the purchaser may experience as a result of installation or use of the product. The buyer's sole remedy for any breach of this agreement or any warranty by Encardio Rite shall not exceed the purchase price paid by the purchaser to Encardio Rite. Under no circumstances will Encardio Rite reimburse the claimant for loss incurred in removing and/or reinstalling equipment.

A lot of effort has been made and precaution for accuracy taken in preparing instruction manuals and software. However best of instruction manuals and software cannot provide for each and every condition in field that may affect performance of the product. Encardio Rite neither assumes responsibility for any omissions or errors that may appear nor assumes liability for any damage or loss that results from use of Encardio Rite products in accordance with the information contained in the manuals or software.

Products described in Encardio Rite's catalogs are subject to modification and improvement as dictated by subsequent developments. Encardio Rite reserves the right to modify, change or improve products, to discontinue them or to add new ones without notice.